

REVISED	DATE	BY
		JEB

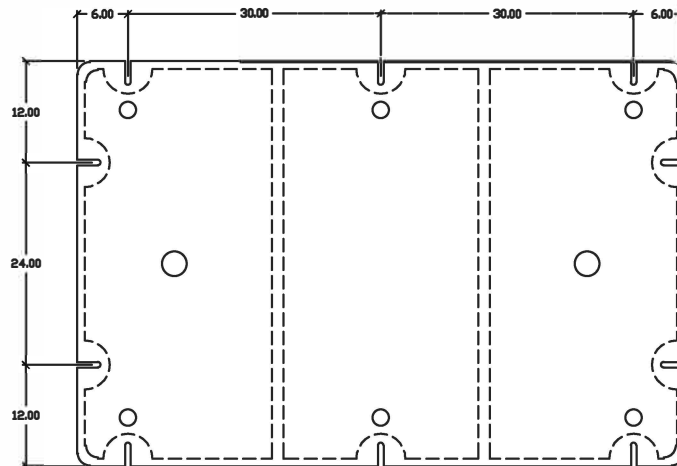

TOP VIEW

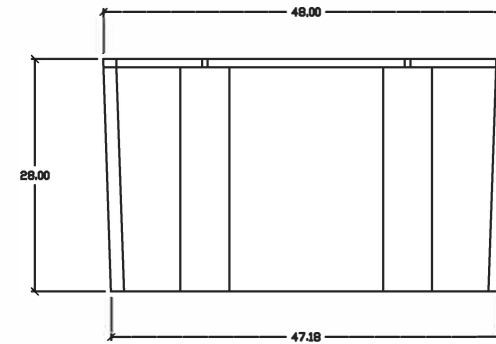
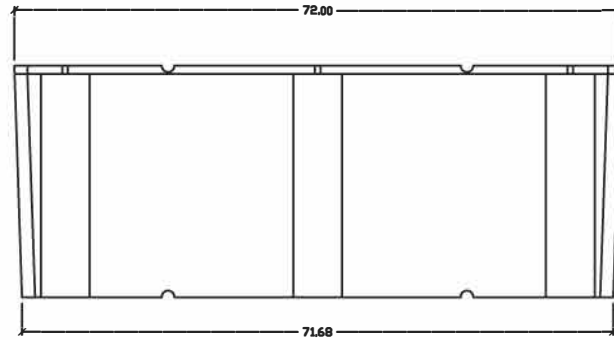
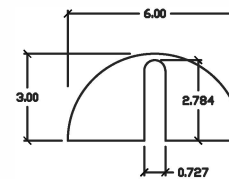

MOUNTING SLOT DETAIL
SCALE 2:1

ALL DIMS NOMINAL

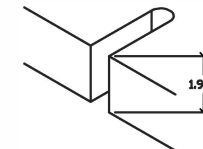

Common technical specs.

Max buoyancy :	3030 LB'S
Nominal wall thickness :	0.15"
Cubic feet:	56.0 FT³
Weight:	131.0 LB.'s

As with all types of materials, allowances must be made for shrinkage and changing of exact dimensions due to temperature and other conditions.

DRAWN BY: JEB APPROVED BY: DATE: 06-23-2014

Materials: Polyethylene encasing Expanded Foam Type:

Part Name: 4'x6'x28"

AutoCad 2010 PART # : EF4628

1 of 1