

| REVISED | DATE | BY |
|---------|------|----|
|         |      |    |
|         |      |    |

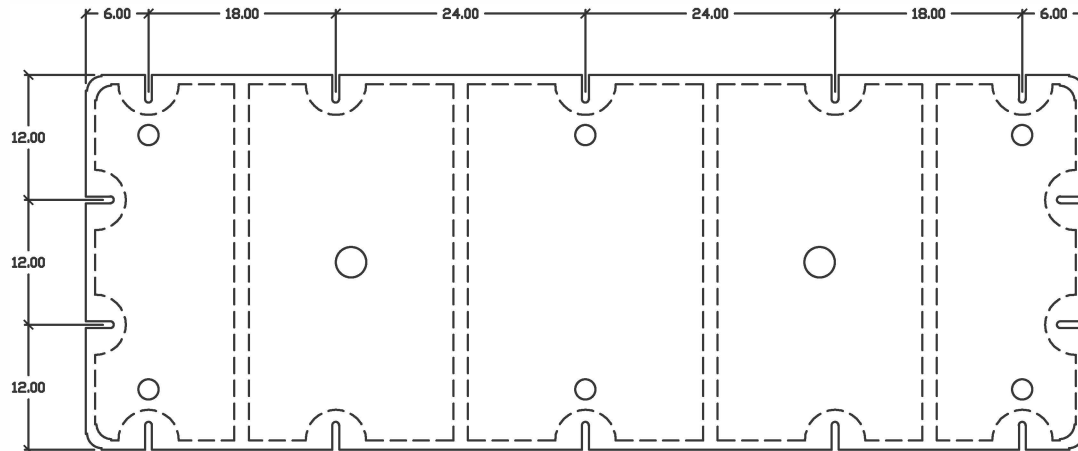

TOP VIEW

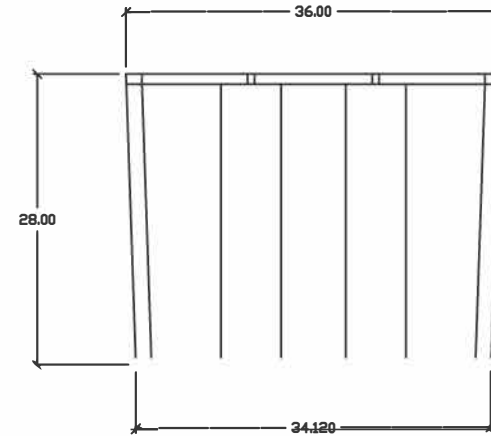
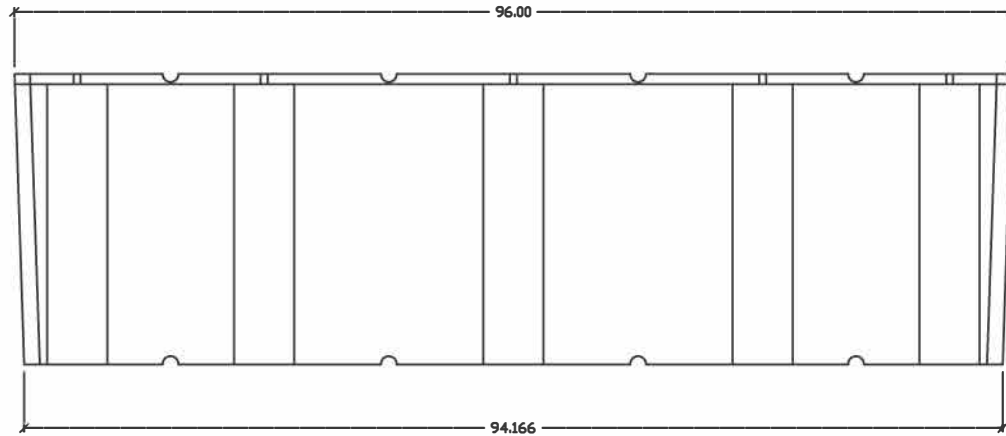
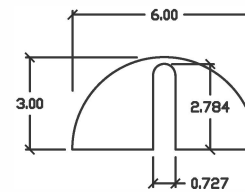

MOUNTING SLOT DETAIL  
SCALE 2:1

ALL DIMS NOMINAL



Common technical specs.

|                          |                      |
|--------------------------|----------------------|
| Max buoyancy :           | 2880 LB'S            |
| Nominal wall thickness : | 0.15"                |
| Cubic feet:              | 56.0 FT <sup>3</sup> |
| Weight:                  | 127.0 LB.'s          |

As with all types of materials, allowances must be made for shrinkage and changing of exact dimensions due to temperature and other conditions.

|                 |             |                  |
|-----------------|-------------|------------------|
| DRAWN BY<br>JEB | APPROVED BY | DATE: 06-19-2014 |
|-----------------|-------------|------------------|

|   |       |
|---|-------|
| Materials: Polyethylene encasing<br>Expanded Foam | Type: |
|---|-------|

Part Name: 3'x8'x28"

|                 |                 |        |
|-----------------|-----------------|--------|
| AutoCad<br>2010 | PART # : EF3828 | 1 of 1 |
|-----------------|-----------------|--------|