

REVISED	DATE	BY

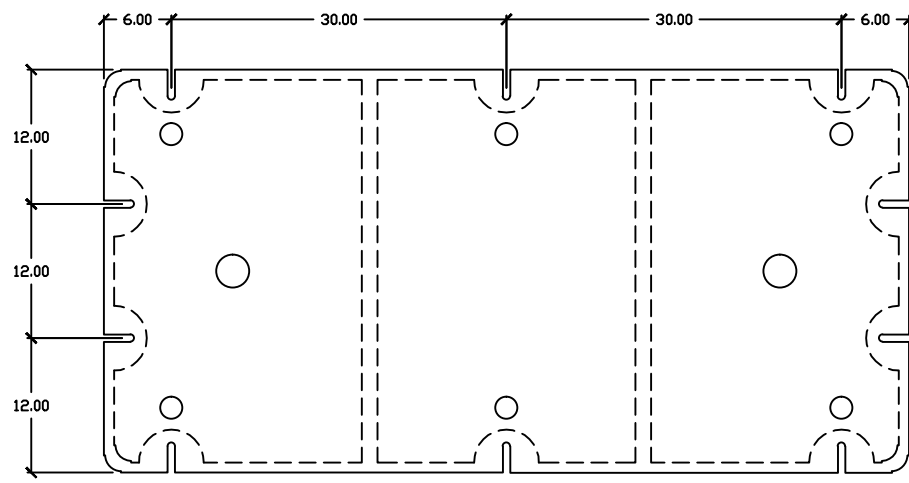

TOP VIEW

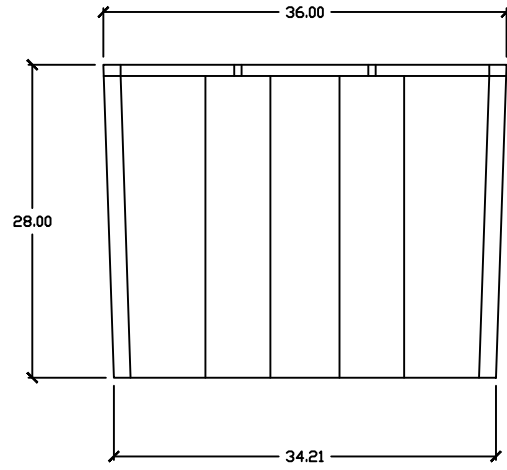
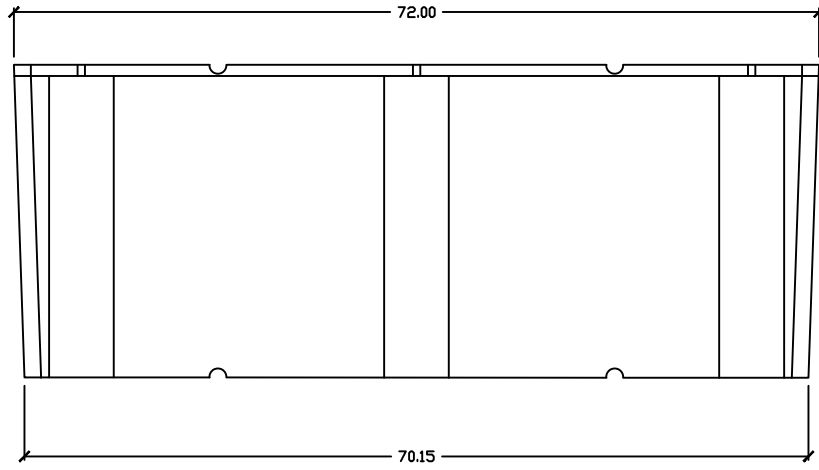
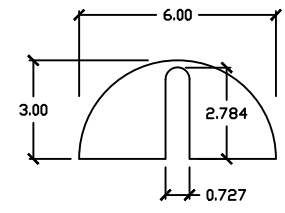

MOUNTING SLOT DETAIL
SCALE 2:1
ALL DIMS NOMINAL

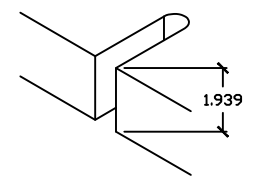

Common technical specs.		
Max buoyancy :	2150 LB'S	
Nominal wall thickness :	0.15"	
Cubic feet:	42.0 FT³	
Weight:	98.0 LB.'s	
DRAWN BY JEB	APPROVED BY	DATE: 06-16-2014
Materials: Polyethylene encasing Expanded Foam		Type:
Part Name: 3'x6'x28"		
AutoCad 2010	PART # : EF3628	1 of 1

As with all types of materials, allowances must be made for shrinkage and changing of exact dimensions due to temperature and other conditions.