

REVISED	DATE	BY

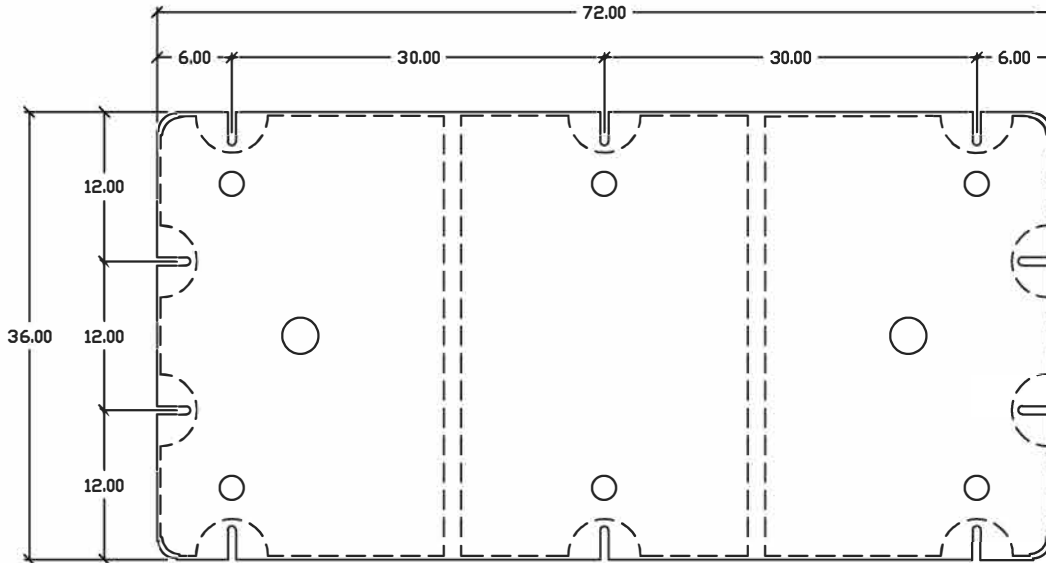

TOP VIEW

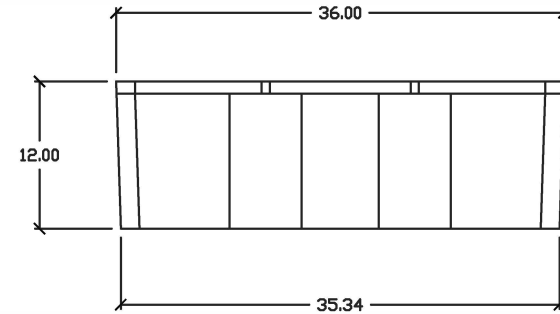
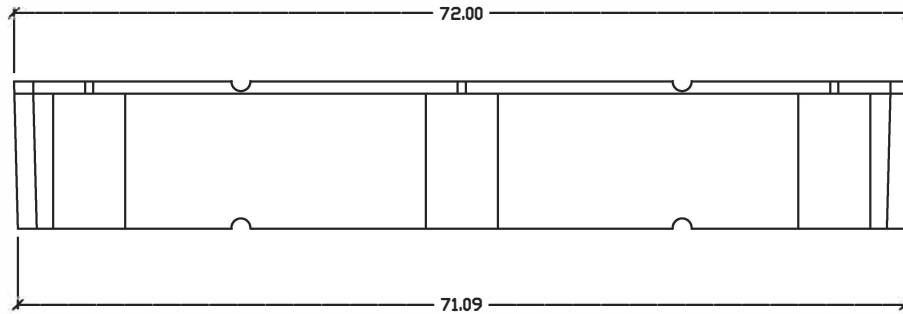
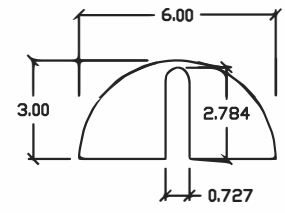

MOUNTING SLOT DETAIL  
SCALE 2:1

ALL DIMS NOMINAL

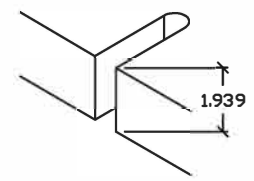

Common technical specs.	
Max buoyancy :	950 LB'S
Nominal wall thickness :	0.15"
Cubic feet:	18.0 FT³
Weight:	57.0 LB.'s

As with all types of materials, allowances must be made for shrinkage and changing of exact dimensions due to temperature and other conditions.

DRAWN BY JEB	APPROVED BY	DATE: 06-16-2014
Materials: Polyethylene encasing Expanded Foam		Type:
Part Name: 3'x6'x12"		
AutoCad 2010	PART # : EF3612	1 of 1