

REVISED	DATE	BY

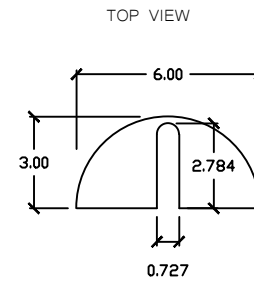

MOUNTING SLOT DETAIL  
SCALE 2:1

ALL DIMS NOMINAL

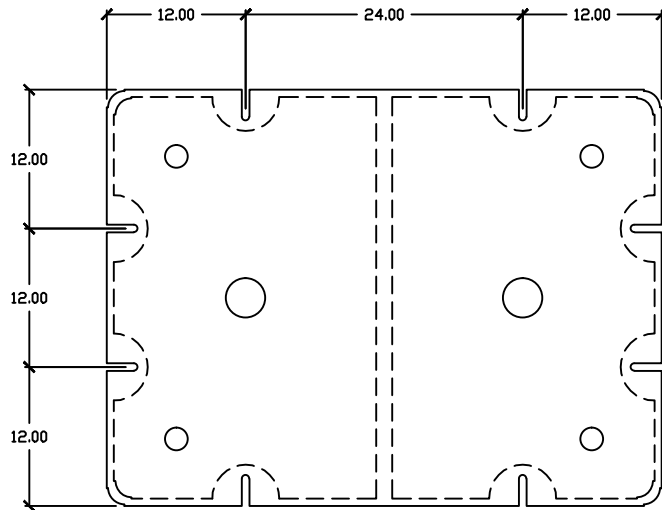
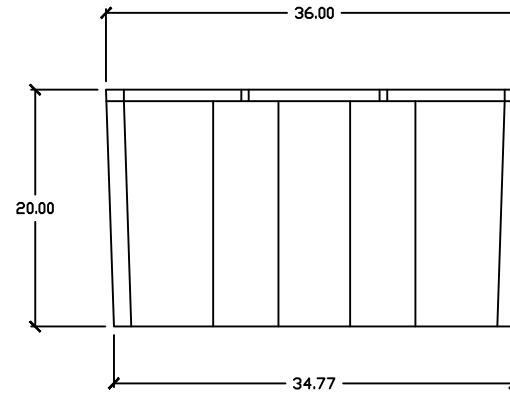
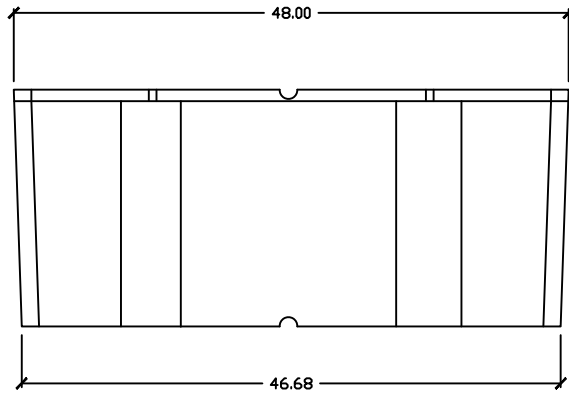
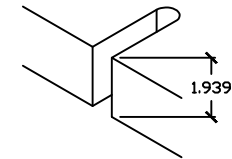

Common technical specs.

Max buoyancy :	1050 LB'S
Nominal wall thickness :	0.15"
Cubic feet:	18.9 FT <sup>3</sup>
Weight:	54.0 LB.'s

As with all types of materials, allowances must be made for shrinkage and changing of exact dimensions due to temperature and other conditions.

DRAWN BY JEB	APPROVED BY	DATE: 06-13-2014
-----------------	-------------	------------------

Materials: Polyethylene encasing Expanded Foam	Type:
---	-------

Part Name: 3'x4'x20"

AutoCad 2010	PART # : EF3420	1 of 1
-----------------	-----------------	--------