

REVISED	DATE	BY

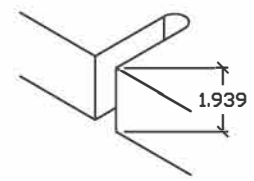
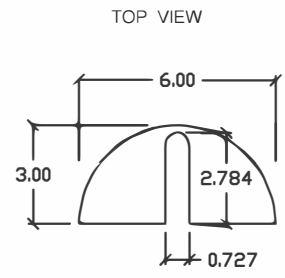
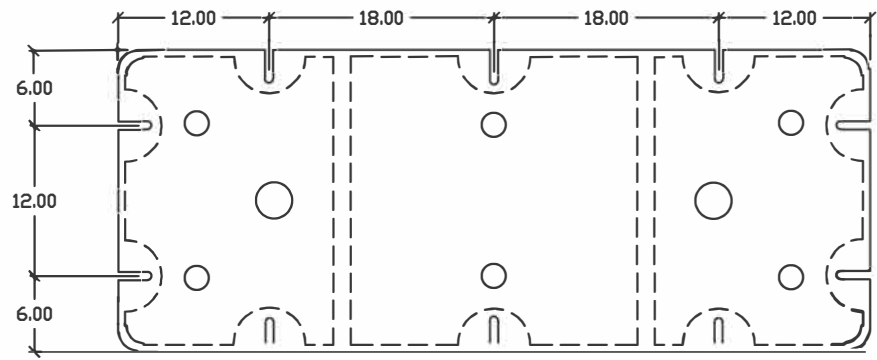
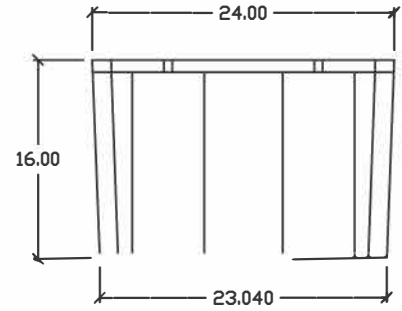
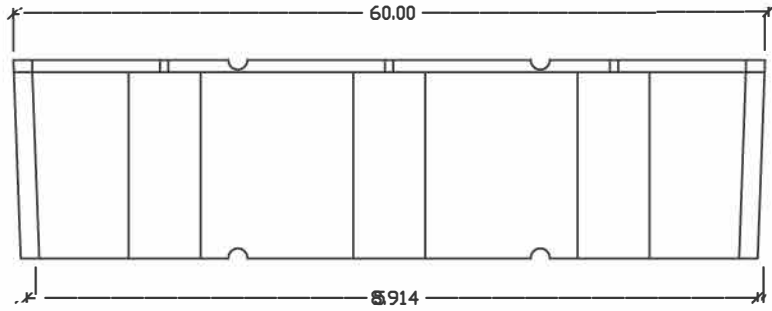

MOUNTING SLOT DETAIL
SCALE 2:1

ALL DIMS NOMINAL

Common technical specs.	
Max buoyancy :	670 LB'S
Nominal wall thickness :	0.15"
Cubic feet:	13.5 FT³
Weight:	43.0 LB.'s

As with all types of materials, allowances must be made for shrinkage and changing of exact dimensions due to temperature and other conditions.

DRAWN BY JEB	APPROVED BY	DATE: 06-06-2014
Materials: Polyethylene encasing Expanded Foam		Type:
Part Name: 2'x5'x16"		
AutoCad 2010	PART # : EF2516	1 of 1