

REVISED	DATE	BY

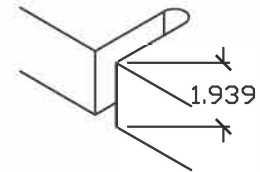
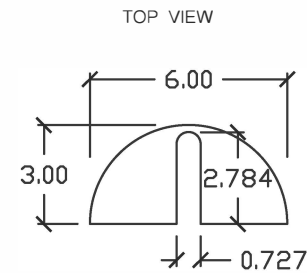
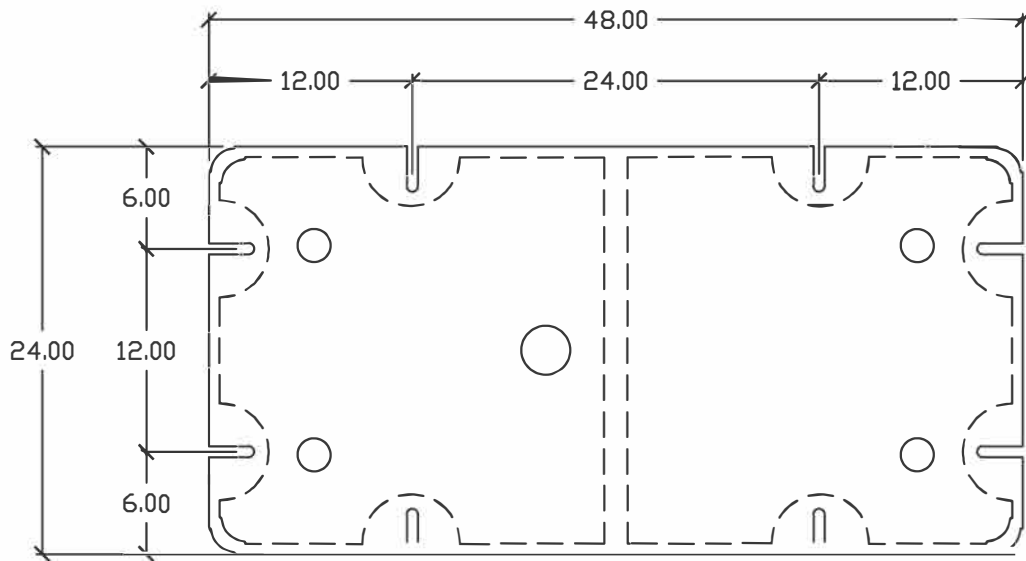
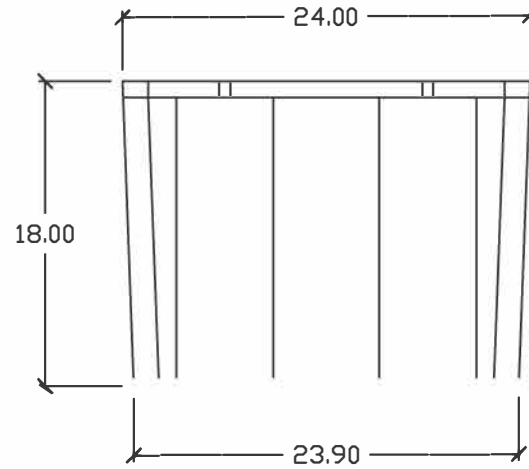
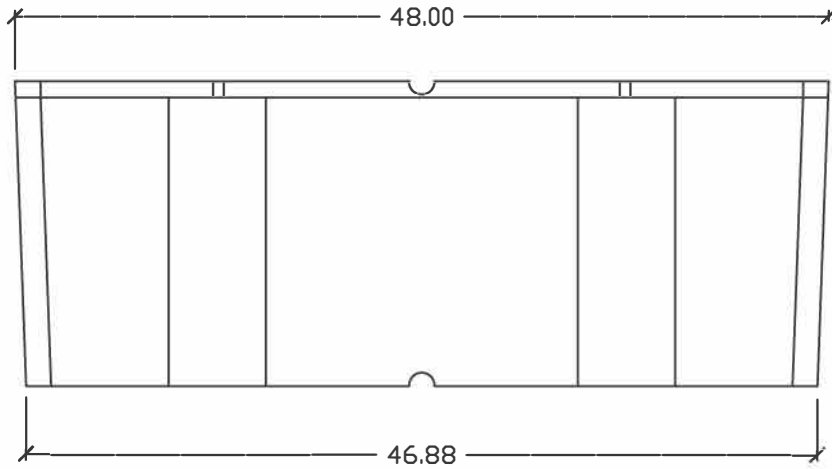

MOUNTING SLOT DETAIL  
SCALE 2:1

ALL DIMS NOMINAL

Common technical specs.	
Max buoyancy :	620 LB'S
Nominal wall thickness :	0.15"
Cubic feet:	12.0 FT <sup>3</sup>
Weight:	37.0 LB.'s

As with all types of materials, allowances must be made for shrinkage and changing of exact dimensions due to temperature and other conditions.

DRAWN BY JEB	APPROVED BY	DATE:
Materials: Polyethylene encasing Expanded Foam		Type:
Part Name: 2'x4'x18"		
AutoCad 2010	PART # : EF2418	1 of 1