

REVISED	DATE	BY

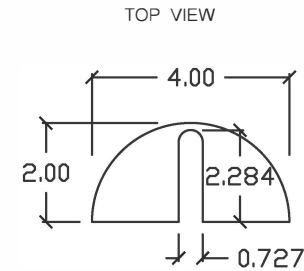

MOUNTING SLOT DETAIL
SCALE 2:1

ALL DIMS NOMINAL

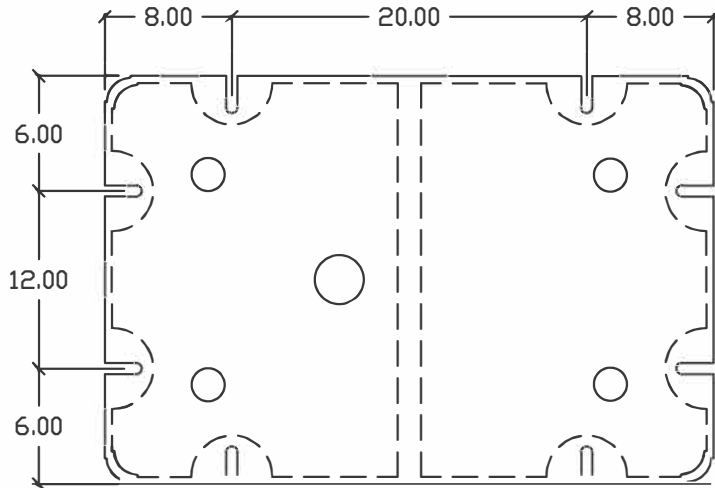
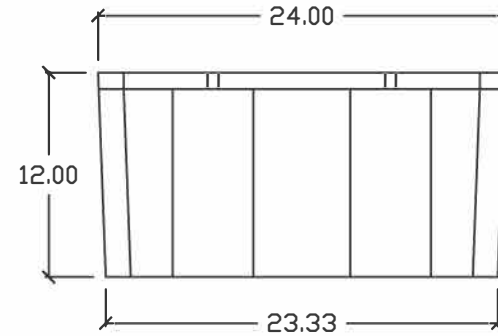
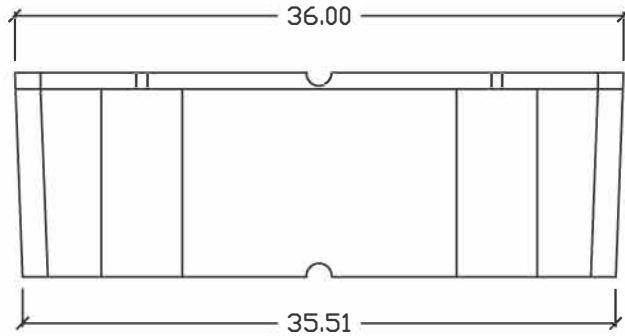
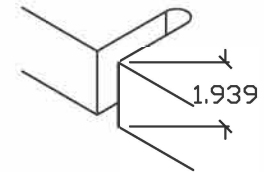

Common technical specs.	
Max buoyancy :	300 LB'S
Nominal wall thickness :	0.15"
Cubic feet:	6.0 FT³
Weight:	26.0 LB.'s
DRAWN BY APPROVED BY JEB	
Materials: Polyethylene encasing Expanded Foam	Type:
Part Name: 2'x3'x12"t	
1 of 1	

As with all types of materials, allowances must be made for shrinkage and changing of exact dimensions due to temperature and other conditions.