

REVISED	DATE	BY

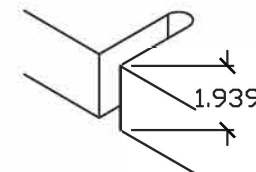
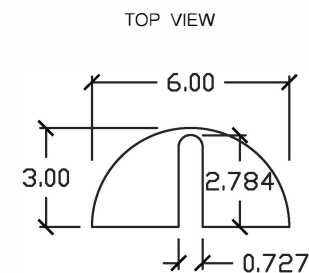
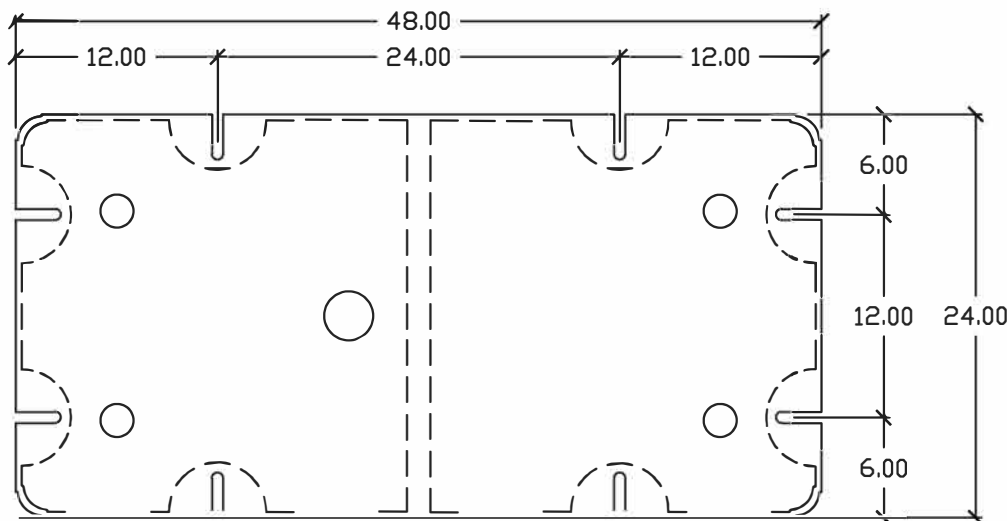
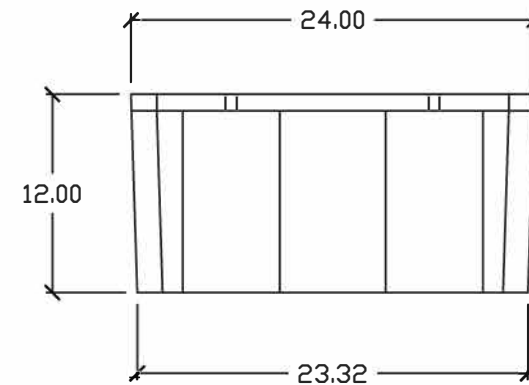
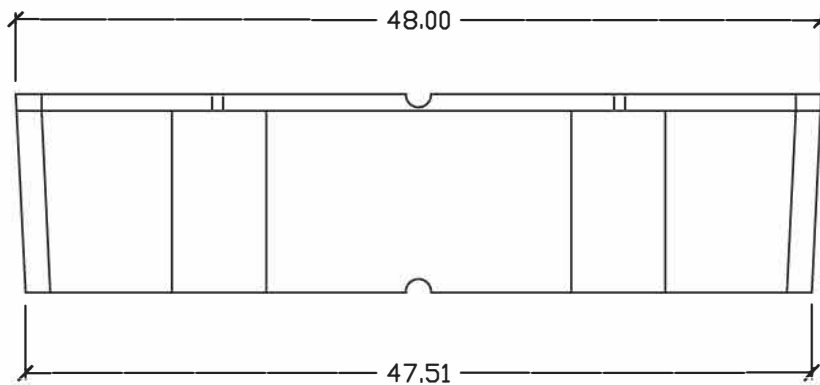

MOUNTING SLOT DETAIL
SCALE 2:1

ALL DIMS NOMINAL

Common technical specs.	
Max buoyancy :	390 LB'S
Nominal wall thickness :	0.15"
Cubic feet:	8.0 FT³
Weight:	31.0 LB.'s
DRAWN BY JEB	APPROVED BY DATE:
Materials: Polyethylene encasing Expanded Foam	Type:
Part Name: 2'x4'x12"	
AutoCad 2010	PART # : EF24 12
	1 of 1

As with all types of materials, allowances must be made for shrinkage and changing of exact dimensions due to temperature and other conditions.