

REVISED	DATE	BY
		JEB

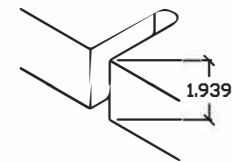
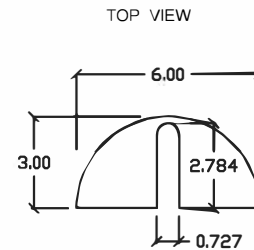
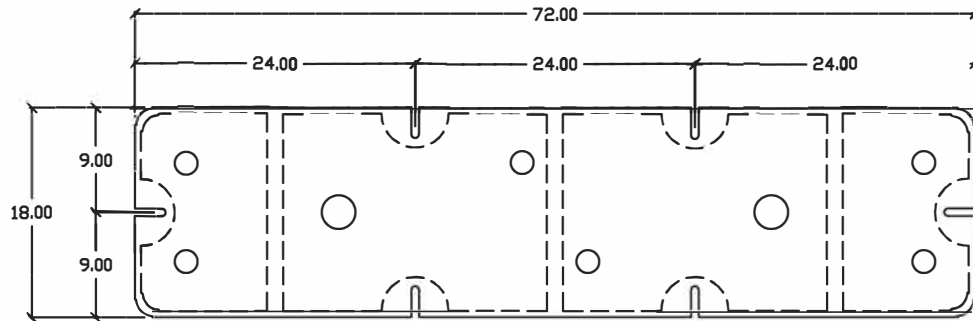
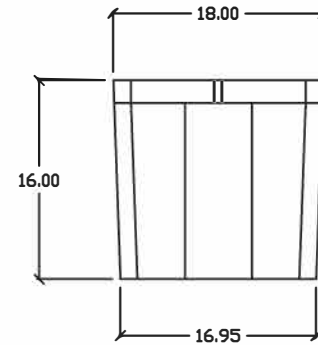
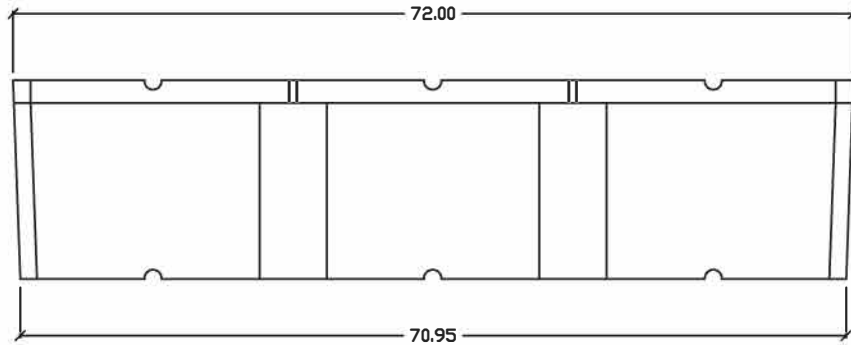

MOUNTING SLOT DETAIL  
SCALE 2:1

ALL DIMS NOMINAL

Common technical specs.

Max buoyancy :	640 LB'S
Nominal wall thickness :	0.15"
Cubic feet:	12.0 FT <sup>3</sup>
Weight:	41.0 LB.'s

As with all types of materials, allowances must be made for shrinkage and changing of exact dimensions due to temperature and other conditions.

DRAWN BY JEB	APPROVED BY	DATE: 06-02-2014
-----------------	-------------	------------------

Materials: Polyethylene encasing Expanded Foam	Type:
---	-------

Part Name: 18"x72"x16"

AutoCad 2010	PART # : EF187216	1 of 1
-----------------	-------------------	--------